

# Pine Research Honeycomb Spectroelectrochemical Cell User Guide



Pine Research Instrumentation  
2741 Campus Walk Avenue  
Building 100  
Durham, NC 27705  
USA

<http://www.pineresearch.com>

Phone: +1 919.782.8320 Fax: +1 919.782.8323

Copyright © 2008 - 2019 Pine Research Instrumentation





# Table of Contents

<b>1. Preface</b>	<b>1</b>
1.1 Scope .....	1
1.2 Copyright.....	1
1.3 Trademarks .....	1
1.4 Use Limitation .....	1
1.5 Harmful or Corrosive Substances .....	2
1.6 Service Information .....	3
1.7 Limited Warranty .....	3
1.8 Icons ( <i> Icônes</i> ).....	4
1.9 General Safety Warnings ( <i>Avertissements de sécurité généraux</i> ).....	4
<b>2. Description</b>	<b>6</b>
<b>3. Specifications</b>	<b>8</b>
3.1 Honeycomb Electrode Card Specifications .....	8
3.2 Quartz Cuvette Specifications .....	8
<b>4. Components</b>	<b>10</b>
4.1 Replacement Parts .....	10
4.2 Accessories.....	11
4.2.1 Gas Purge Kits .....	11
4.2.2 Reference Electrodes .....	11
<b>5. Cell Assembly</b>	<b>13</b>
5.1 Pre-Assembly .....	13
5.2 Fill the Cell with Solution.....	14
5.3 Place Cuvette in Cuvette Holder .....	15
5.4 Potentiostat Connection.....	16
5.4.1 Connecting to a WaveNow/WaveNano Potentiostat.....	16
5.4.2 Connecting to a WaveDriver 10/20 Potentiostat .....	16
5.4.3 Connection to a WaveDriver 40/100/200 Potentiostat .....	16
5.4.4 Connection to a Third-Party Potentiostat.....	17
5.5 Light Source/Spectrometer Connection .....	19
<b>6. Example Experiments</b>	<b>20</b>
6.1 Basic Spectroelectrochemical Experiments.....	20
6.1.1 Ferricyanide/Ferrocyanide .....	20
6.1.2 Methyl Viologen .....	23
6.2 Measurement of Electrochemical Kinetics.....	25

<b>7. Care and Storage</b>	<b>26</b>
7.1 Component Storage.....	26
7.2 Cleaning the Quartz Cell .....	26
7.3 Cleaning the Cell Cap .....	26
7.4 Cleaning the Honeycomb Electrode.....	26
7.4.1 Chemical Methods.....	26
7.4.2 Electrochemical Method .....	27
<b>8. Bibliography</b>	<b>29</b>
<b>9. Glossary</b>	<b>31</b>
<b>10. Contact Support</b>	<b>33</b>
10.1 Online.....	33
10.2 By E-mail.....	33
10.3 By Phone.....	33

---

## 1. Preface

### 1.1 Scope

This User Guide describes the Honeycomb UV/Vis Spectroelectrochemical Cell Kit, hereafter referred to as the “Honeycomb Cell”. This guide is written for the professional scientist or engineer (or student of science and engineering) and assumes a basic knowledge of scientific measurement. Portions of this document devoted to electrochemistry and spectroscopy assume some prior familiarity with these subjects.

### 1.2 Copyright

This publication may not be reproduced or transmitted in any form, electronic or mechanical, including photocopying, recording, storing in an information retrieval system, or translating, in whole or in part, without the prior written consent of Pine Research Instrumentation.

### 1.3 Trademarks

All trademarks are the property of their respective owners. *Windows* is a registered trademark of Microsoft Corporation (Redmond, WA). *WaveNow®*, *WaveDriver®*, and *AfterMath®* are registered trademarks of Pine Research Instrumentation (Durham, NC).

### 1.4 Use Limitation

The Honeycomb UV/Vis Spectroelectrochemical Cell Kit is not designed for use in experiments involving human subjects and/or the use of electrodes inside or on the surface of the human body.

Any use of this system other than its intended purpose is prohibited.

## 1.5 Harmful or Corrosive Substances

The researcher using the Honeycomb UV/Vis Spectroelectrochemical Cell Kit should have prior experience working in a chemical laboratory and knowledge of the safety issues associated with working in chemical laboratory. Electrochemical experiments may involve the use of harmful or corrosive substances, and the operator should wear personal protective equipment while working with these substances. At a minimum, the operator should wear the following items to avoid contact with harmful or corrosive substances:

- Eye protection (safety goggles, face shield, etc.)
- Laboratory coat (flame resistant and solvent resistant)
- Solvent-resistant gloves
- Closed-toe shoes

Additional personal protective clothing and equipment may be required depending upon the nature of the chemicals used in an experiment. A complete discussion of chemical laboratory safety practices is beyond the scope of this user guide, and the reader is directed to the CHEMICAL SAFETY BIBLIOGRAPHY below for additional information.

### CHEMICAL SAFETY BIBLIOGRAPHY BIBLIOGRAPHIE DE SÉCURITÉ CHIMIQUE

1. American Chemical Society Committee on Chemical Safety Hazards Identification and Evaluation Task Force, *Identifying and Evaluating Hazards in Research Laboratories: Guidelines Developed by the Hazards Identification and Evaluation Task Force of the ACS Committee on Chemical Safety*; American Chemical Society, 2013.
2. National Research Council (US), Division of Earth and Life Studies, Board of Chemical Sciences and Technology, Committee on Prudent Practices in the Laboratory, *Prudent Practices in the Laboratory: Handling and Management of Chemical Hazards, Updated Version*; National Academies Press, 2011.
3. American Chemical Society Committee on Chemical Safety. *Safety in Academic Chemistry Laboratories*; 7th ed.; American Chemical Society: State College, PA, 2003; Vol. 2.

L'opérateur du WaveDriver 100 doit avoir une expérience préalable de travail dans un laboratoire de chimie et la connaissance des mesures de sécurité associées aux travaux dans un laboratoire de chimie. Les expériences en électrochimie peuvent impliquer l'utilisation de substances nocives ou corrosives, et l'opérateur doit porter des équipements de protection individuelle lorsqu'il travaille avec ces substances. Au minimum, l'opérateur doit porter les articles suivants pour éviter le contact avec les substances nocives ou corrosives :

- Protection des yeux (lunettes de sécurité, masque de protection facial, ect.)
- Blouse de laboratoire (résistante au feu et résistante aux solvants)
- Gants de protection résistants aux solvants
- Chaussures fermées

Des vêtements et équipements de protection individuelle supplémentaires peuvent être requis en fonction de la nature des produits chimiques utilisés dans une expérience. Une discussion complète des pratiques de sécurité de laboratoire chimique est au-delà de la portée de ce guide de l'utilisateur, et le lecteur est dirigé vers la « BIBLIOGRAPHIE DE SÉCURITÉ CHIMIQUE » ci-dessus pour des informations supplémentaires.

## 1.6 Service Information



### RETURN MATERIAL AUTHORIZATION REQUIRED!

Do not ship equipment to the factory without first obtaining a Return Material Authorization (RMA) from Pine Research Instrumentation.

For questions about proper operation of the Honeycomb UV/Vis Spectroelectrochemical Cell Kit or other technical issues, please use the contact information below to contact Pine Research directly.

### TECHNICAL SERVICE CONTACT

Pine Research Instrumentation, Inc.  
<http://www.pineresearch.com>  
Phone: +1 (919) 782-8320  
Fax: +1 (919) 782-8323

If the Honeycomb UV/Vis Spectroelectrochemical Cell Kit or one of its components or accessories must be returned to the factory for service, please contact Technical Service (above) to obtain a Return Material Authorization (RMA) form. Include a copy of this RMA form in each shipping carton and ship the cartons to the Factory Return Service Address (below).

### FACTORY RETURN SERVICE ADDRESS

Pine Instrument Company  
ATTN: RMA # <RMA number>  
104 Industrial Drive  
Grove City, PA 16127  
USA

## 1.7 Limited Warranty

### LIMITED WARRANTY

The Honeycomb Spectroelectrochemical Cell Kit (hereafter referred to as the "CELL KIT") offered by Pine Research Instrumentation (hereafter referred to as "PINE") is warranted to be free from defects in material at the time of shipment to CUSTOMER. No part of the CELL KIT is specifically warranted beyond the date received by the CUSTOMER.

This warranty being expressly in lieu of all other warranties, expressed or implied and all other liabilities.





All specifications are subject to change without notice. The CUSTOMER is responsible for charges associated with non-warranted repairs. This obligation includes but is not limited to travel expenses, labor, parts and freight charges.



## 1.8 Icons (Icônes)

Special icons are used to call attention to safety warnings and other useful information found in this document (see: Table 1-1).

*Des icônes spéciales (voir: tableau 1-1) sont utilisées pour attirer l'attention sur des avertissements de sécurité et autres renseignements utiles disponibles dans ce document.*

	<p><b>CAUTION:</b> Indicates information needed to prevent injury or death to a person or to prevent damage to equipment.</p> <p><b>ATTENTION:</b> <i>Indique les informations nécessaires à la prévention de blessures corporelles ou de mort d'un individu ou à la prévention des dommages aux équipements.</i></p>
	<p><b>STOP:</b> For a procedure involving user action or activity, this icon indicates a point in the procedure where the user must stop the procedure.</p> <p><b>ARRÊT:</b> <i>Dans une opération impliquant l'action ou l'activité d'un utilisateur, cette icône indique la partie de l'opération où l'utilisateur doit arrêter l'opération.</i></p>
	<p><b>NOTE:</b> Important or supplemental information.</p> <p><b>REMARQUE:</b> <i>Renseignements importants ou complémentaires.</i></p>
	<p><b>TIP:</b> Useful hint or advice.</p> <p><b>CONSEIL:</b> <i>Astuce ou conseil utile.</i></p>











**Table 1-1. Special Icons used in this Document.**

**(Tableau 1-1. Icônes spéciales utilisées dans ce document)**

## 1.9 General Safety Warnings (Avertissements de sécurité généraux)

Spectroelectrochemical experiments involve potentiostat and spectrometer instrumentation. The general safety warnings below apply to the use of both types of instruments.



	<p><b>WARNING:</b></p> <p>There are no user serviceable components inside the potentiostat or the spectrometer instrumentation. Do not remove the chassis covers on these instruments. Refer any service issue to qualified personnel.</p>
	<p><b>WARNING:</b></p> <p>Factory-approved power supplies are provided with the potentiostat and the spectrometer instrumentation. Do not use a power supply which is not factory-approved.</p>
	<p><b>WARNING:</b></p> <p>Connect each instrument power supply to the AC mains using the power cords supplied with each instrument. Do not replace these power cords with inadequately rated cords.</p>
	<p><b>WARNING:</b></p> <p>Do not block access to the instrument power supply or the power cord. The user must have access to disconnect the power supply or the power cord from the AC mains at all times.</p>
	<p><b>WARNING:</b></p> <p>Do not block access to the power switch located on the potentiostat or the power switch located on the spectrometer. The user must have access to these instrument power switches at all times.</p>
	<p><b>WARNING:</b></p> <p>Do not operate the potentiostat or the spectrometer in an explosive atmosphere.</p>
	<p><b>CAUTION</b></p> <p>Provide proper ventilation for the potentiostat and for the spectrometer. Maintain at least two inches (50 mm) of clearance around the sides (left, right, and back) and above (top) of these instruments.</p>
	<p><b>CAUTION:</b></p> <p>Do not operate the potentiostat or the spectrometer in wet or damp conditions. Keep all instrument surfaces clean and dry.</p>
	<p><b>CAUTION:</b></p> <p>Do not operate an instrument (potentiostat or spectrometer) if the instrument has suffered damage or is suspected of having failed. Refer the instrument to qualified service personnel for inspection.</p>
	<p><b>WARNING:</b></p> <p>Some procedures described in this user guide require the use of corrosive chemical solutions. Wear proper personal protective equipment when working with corrosive solutions.</p>

## 2. Description

The Honeycomb Spectroelectrochemical Cell Kit from Pine Research consists of several components specially designed to simultaneously interrogate the spectroscopic and electrochemical properties of chemical species. The principle components of the kit are a honeycomb patterned electrode card and a thin-layer quartz cuvette (see: Figure 2-1A). The cuvette has a plastic cap which securely holds the top of the honeycomb electrode card (see: Figure 2-1B) and the top of a separate reference electrode (see: Figure 2-1C) in the proper position within the cuvette.



**Figure 2-1. Beam Path and Electrical Connections for the Honeycomb Electrode**

Electrode cards with gold or platinum metal patterns are available. The metal pattern on the electrode card includes both the working electrode (see: Figure 2-2 A) and two counter electrode bands (see: Figure 2-2 B&C). Electrical connections to the electrode card are made via a convenient mini-B USB connector. Connection to the reference electrode is made via a simple pin connection which can accept either an alligator clip or a pin-and-socket connection.

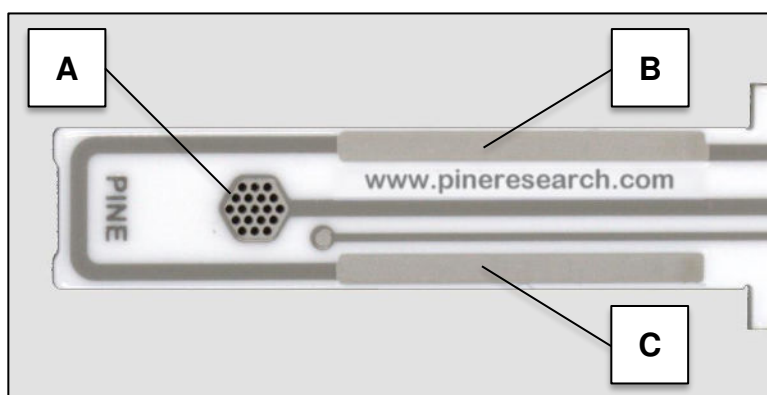
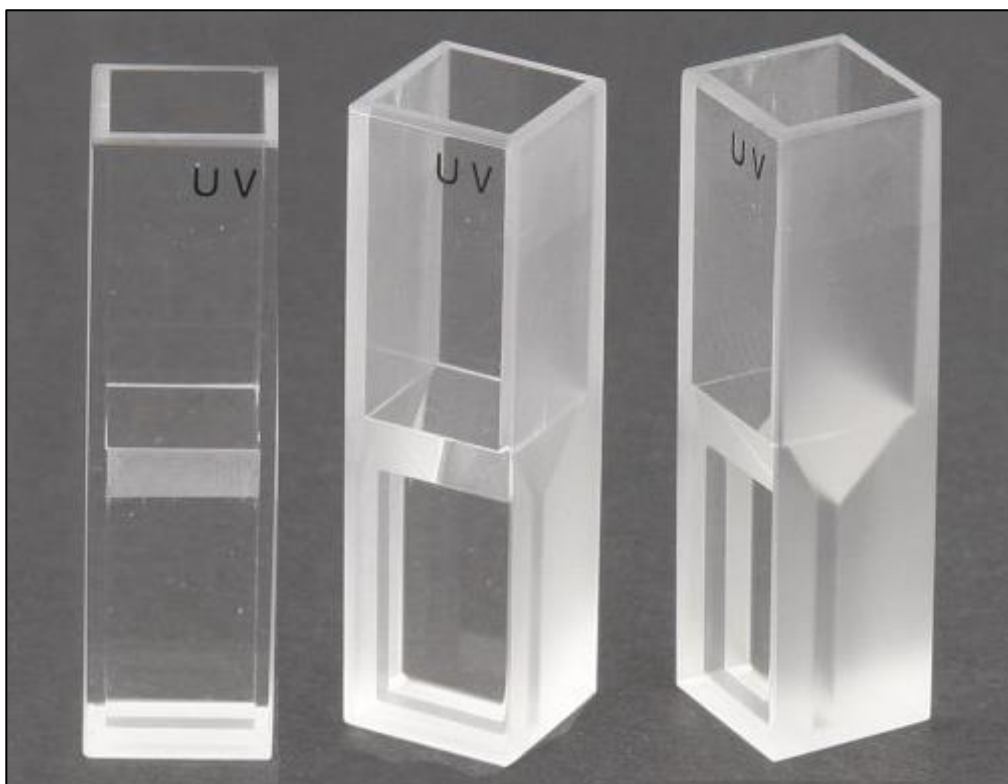

**Figure 2-2. Location of Working and Counter Electrodes**

The working electrode pattern is perforated with a honeycomb hole pattern (see: Figure 2-2 A). From a spectroscopic perspective, these holes allow light to pass through the working electrode when the electrode card is placed in the beam path of a spectrometer (see: Figure 2-1A). From an electrochemical perspective, the active surface of the working electrode includes both the metal

coating on the outer (flat) surface of the electrode card, and more importantly, the metal coating along the inner walls of the holes.

The portion of solution adjacent to these inner walls is subject to simultaneous electrochemical interrogation (by the potentiostat) and optical interrogation (by the spectrometer). As the light beam from the spectrometer passes through the holes, the beam grazes the inner wall of each hole. The beam travels a relatively long path along these inner walls, so that the spectroscopic measurement samples a significant portion of solution in direct contact with the electrode surface. The potentiostat can be used to induce an electrochemical process at the electrode surface which changes the light absorbing properties of the solution. The spectrometer can be used to monitor the amount of light absorbed by the solution as the potentiostat monitors (or controls) the potential (or current) at the working electrode.

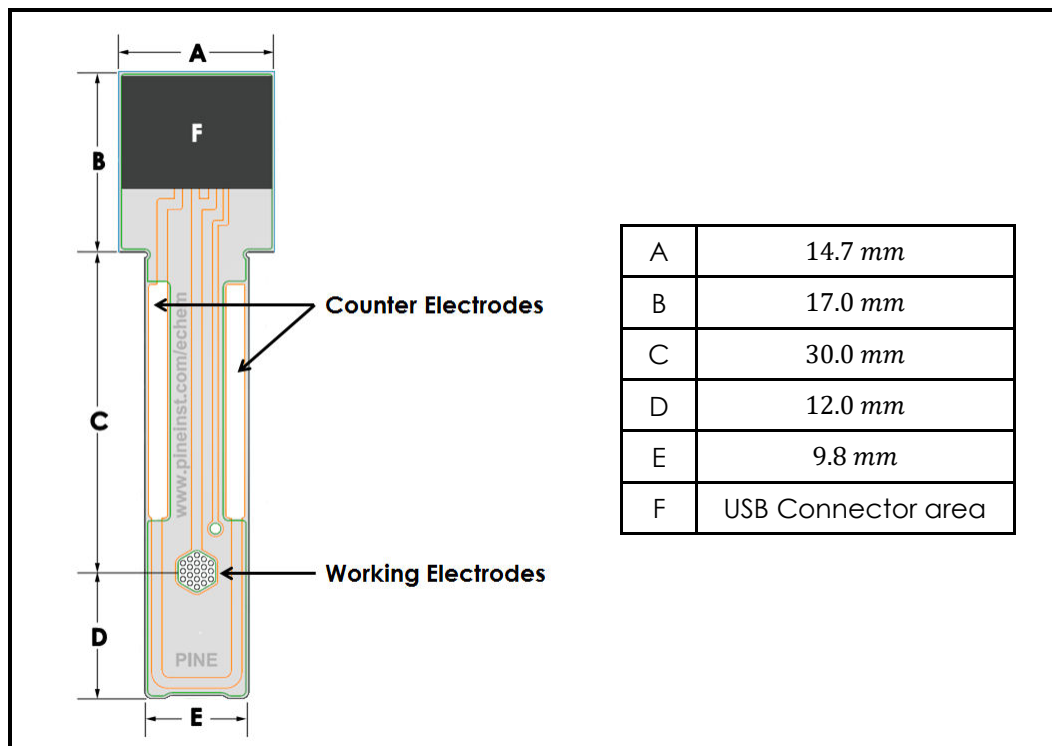

**Figure 2-3. Photograph of the Quartz Cuvette at Several Angles**

## 3. Specifications

### 3.1 Honeycomb Electrode Card Specifications

Each electrode card is a ceramic substrate adorned with a metal electrode pattern (either gold or platinum) and a clear coating of silicon dioxide. The silicon dioxide layer insulates all but the active areas of the counter and working electrodes (see: Figure 3-1).



**Figure 3-1. Schematic and Dimensions of a Honeycomb Electrode Card**

The working electrode is perforated with nineteen (19) holes arranged in a honeycomb pattern. The inner walls of each hole are also coated with metal and are an active part of the working electrode surface. Each hole is 0.50 mm in diameter with a center-to-center distance of 0.75 mm and an effective path length of 1.7 mm. The counter electrode consists of two exposed metal bands (electrically connected to each other) located above the working electrode hole pattern.

### 3.2 Quartz Cuvette Specifications

The thin-layer quartz cuvette features a slot near the bottom of the cuvette designed to accept a honeycomb electrode card (see: Figure 3-2). This slot prevents electrogenerated species from diffusing away from the electrode during a spectroelectrochemistry experiment, improving the absorbance signal measured by the spectrometer. The quartz cuvette has a 1 cm × 1 cm footprint, which is the standard size compatible with most UV-Vis cuvette holders.

The maximum solution volume held by the cuvette when the electrode card is not in the cuvette is 2.8 mL. If the electrode card is inserted into the cuvette, then the maximum solution volume for proper operation is reduced to approximately 2 mL. It is possible to use even smaller volumes of solution as long as the solution entirely covers the honeycomb working electrode and partially covers the counter electrode bands.

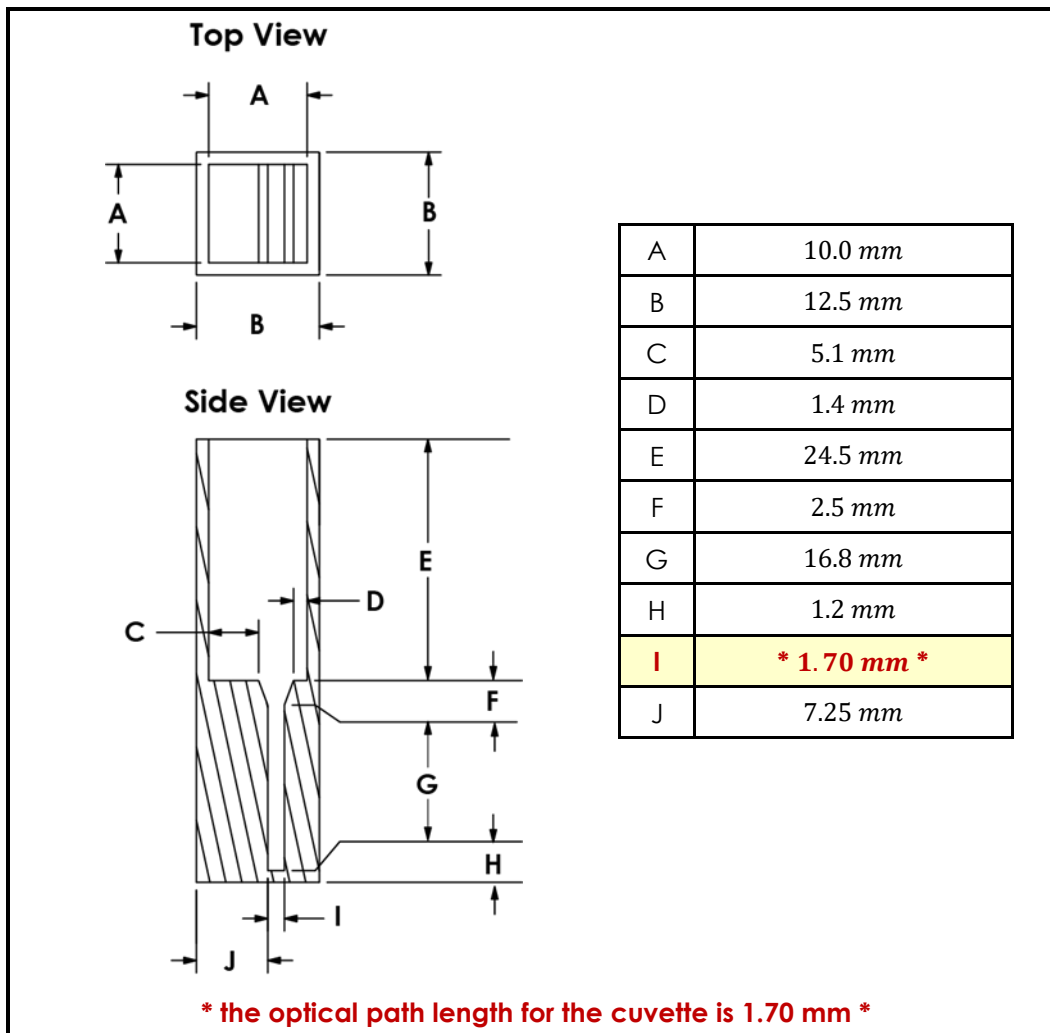

Figure 3-2. Schematic and Dimensions of the Thin-Layer Quartz Cuvette

## 4. Components

### 4.1 Replacement Parts

Each Honeycomb Spectroelectrochemical Cell Kit from Pine Research includes a cell cap, quartz cuvette, three Honeycomb electrode cards, and a reference electrode. Each component can be purchased individually to supplement or replace parts from the original kit (see: Figure 4-1).

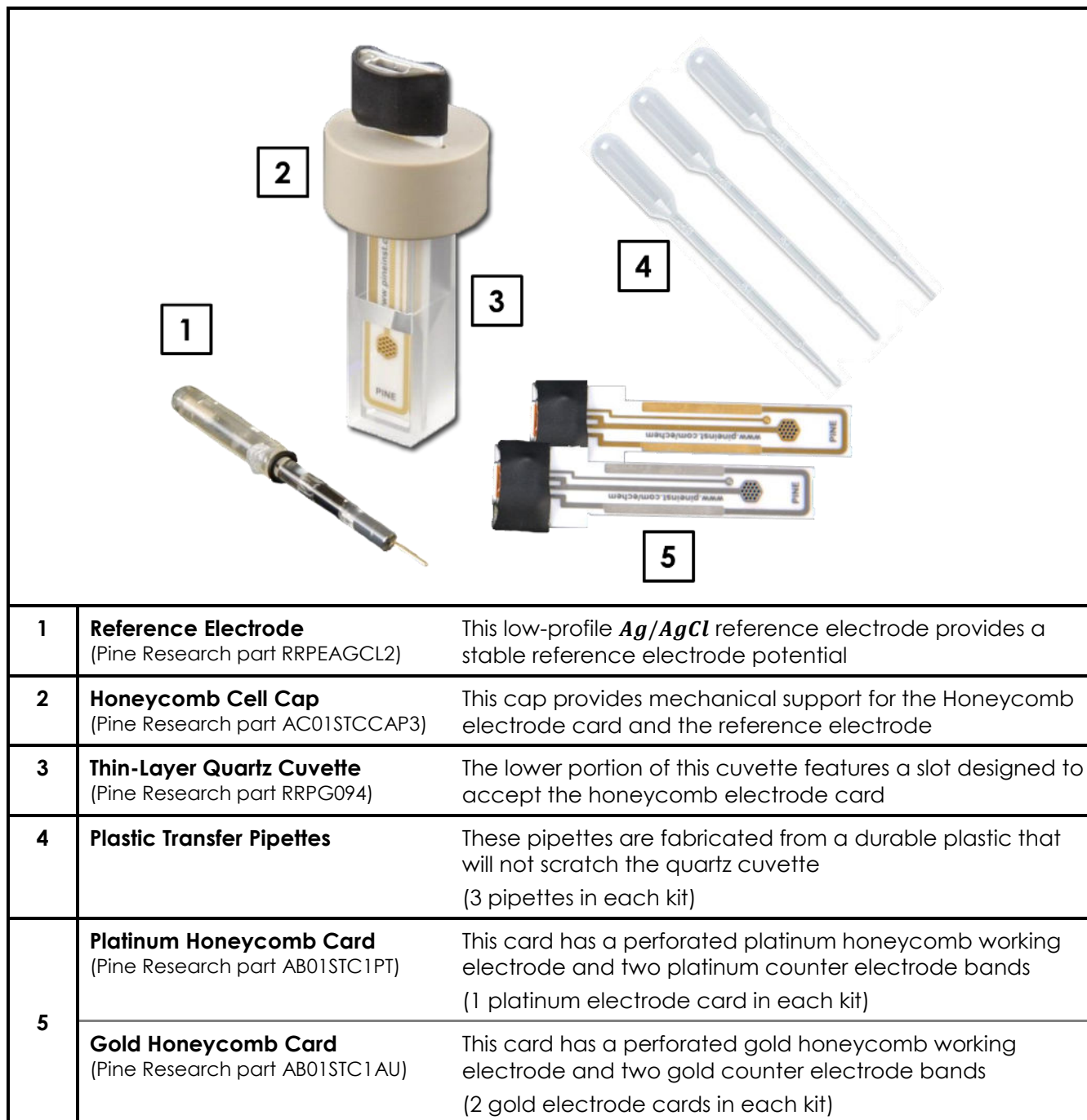

Figure 4-1. Honeycomb Spectroelectrochemical Cell Kit Components

## 4.2 Accessories

The Honeycomb Spectroelectrochemistry Cell is normally used in conjunction with a potentiostat and a spectrometer. Pine Research manufactures several potentiostat models and is also able to offer UV/Visible spectrometer systems which work in conjunction with Pine Research potentiostats. In addition to these two instruments, there are several other accessories offered by Pine Research which may assist with certain spectroelectrochemistry experiments.

### 4.2.1 Gas Purge Kits

Pine Research offers gas purge kits to assist with cell solution purging, sparging, and blanketing. For the Honeycomb Spectroelectrochemistry Cell, two purge kits are necessary for gas addition/removal:

- Three-Way Valve Purge Kit (Pine Research part AKPURGE1, see: Figure 4-2)
- Micro-Connection Purge Kit (Pine Research part AKPURGE2, see: Figure 4-3)

The Three-Way Valve Purge Kit consists of 1/4" ID PVC tubing and a three-way valve. The three-way valve makes it possible to switch between bubbling and blanketing the solution with an inert gas. The Micro-Connection Purge Kit consists of microtubing and adapters that work with the Three-Way Valve Purge Kit to deliver a flowing gas stream to the appropriate openings on the cell cap.

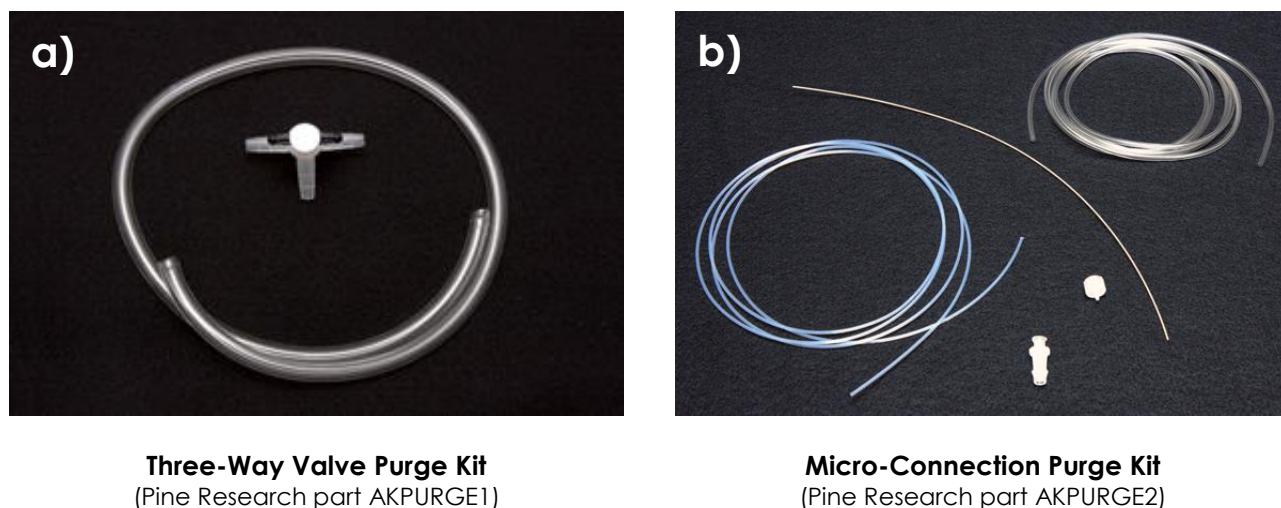
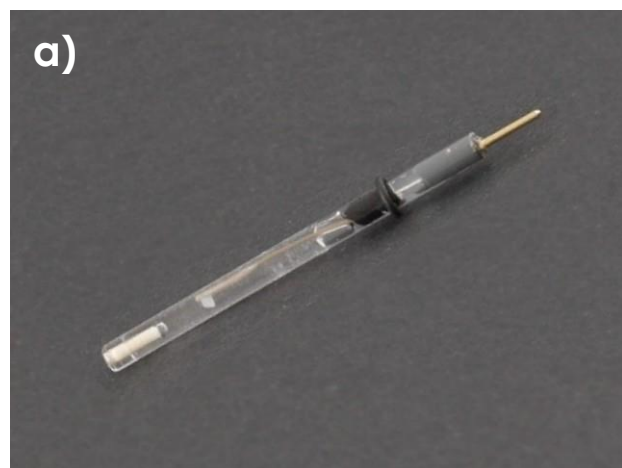

**Figure 4-2. Pine Research Gas Purge Kits**

### 4.2.2 Reference Electrodes

The Honeycomb Spectroelectrochemical Cell Kit includes a low-profile silver chloride (Ag/AgCl) reference electrode. This Ag/AgCl electrode is ideal for aqueous solvent systems in situations where chloride ion contamination is not of concern. The dimensions of this reference electrode are 3.5 mm OD×60 mm long (see: Figure 4-3A).

An alternate low-profile silver wire pseudo-reference electrode is available. This electrode may be filled with any solution which is compatible with the electrolyte solution in the cuvette (see: Figure 4-3B).



**Aqueous Ag/AgCl Reference Electrode**  
(Pine Research part RRPEAGCL2)



**Silver Wire Pseudo-Reference Electrode**  
(Pine Research part RREF0153L2)

**Figure 4-3. Low Profile Reference Electrodes for Spectroelectrochemistry**



## 5. Cell Assembly

The Honeycomb Electrode Cell Kit has four main parts: the quartz cuvette, the electrode care, reference electrode, and cell cap. This section will detail how to assemble these components and subsequently fill the cell with solution.

**CAUTION:**

The quartz cuvette is fragile and has thin walls.  
Use extreme caution when handling the cell.

**INFO:**

A replacement quartz cuvette may be purchased separately from Pine Research Instrumentation.

Note that such a replacement is not covered by any warranty.

### 5.1 Pre-Assembly

To see how the components fit together, fit the cell cap over the quartz cuvette, making sure that the slot on the cap and the slot in the cuvette are aligned (see: Figure 5-1, left & middle). Then, insert an electrode card into the empty slot in the cell cap. The electrode card should be aligned with the groove in the quartz cell and oriented so that the patterned side of the electrode is closer to the wall of the cuvette than the non-patterned side (see: Figure 5-1, right).



Figure 5-1. Proper Slot Alignment for the Quartz Cuvette, the Cap, and the Electrode Card

## 5.2 Fill the Cell with Solution



### STOP:

The next part of this procedure details how to fill the cuvette with solution. To obtain background scans (UV/Vis and/or electrochemical), fill the cuvette with blank electrolyte solution.

Use a plastic pipette to fill the quartz cuvette with solution. The cuvette can be filled through the large bore hole in the cell cap or by completely removing the cell cap. It is easiest to fill the cuvette before inserting the electrode card (see: Figure 5-2). The total fill volume should be approximately 1.2 mL.

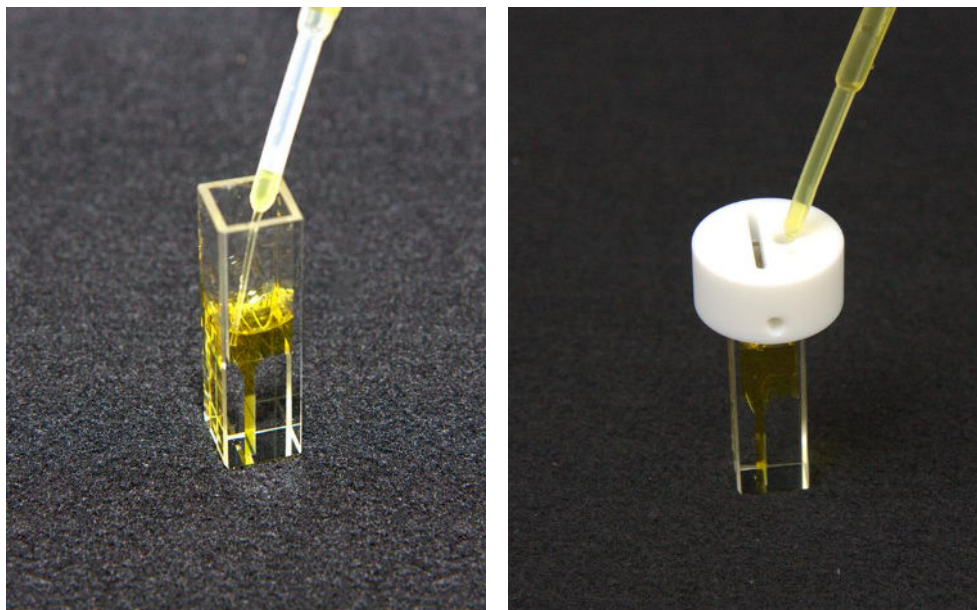

**Figure 5-2. Filling the Quartz Cuvette with Solution**

Before placing the electrode card back into the cuvette, pre-fill the honeycomb holes in the electrode card with the solution. Check to be sure that no air pockets are trapped inside any of the holes (see: Figure 5-3).

Then, insert the electrode card into the cell cap assembly. The side of the card with the metal pattern should point away from the fill hole in the cap. (Later, when the cuvette is mounted in the spectrometer, the side of the card with the metal pattern should face the incoming light.)



**Figure 5-3. Fill the Holes with Solution**

Finally, insert the reference electrode (LowProfile  $Ag/AgCl$  Gel or Pseudo  $Ag$  Wire) and use the O-ring to adjust the immersion depth (see: Figure 5-4).

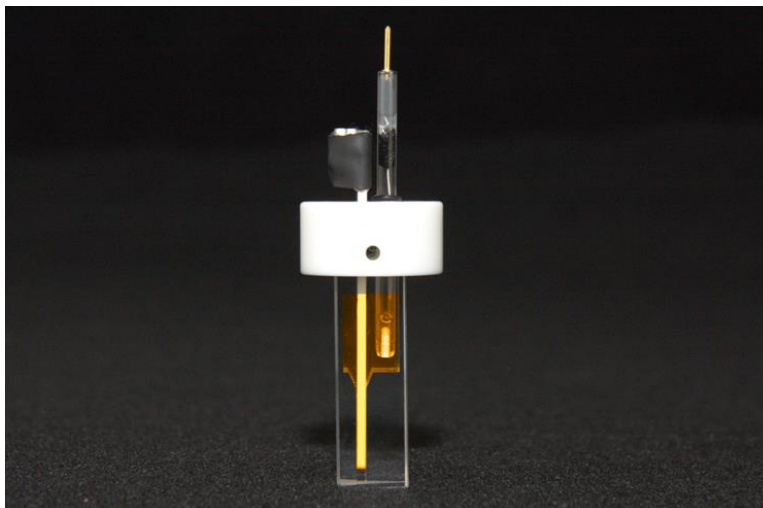

**Figure 5-4. Fully Assembled Honeycomb Spectroelectrochemical Cell with Solution**

### 5.3 Place Cuvette in Cuvette Holder

Ensure that the cuvette is placed in the cuvette holder with the patterned side of the electrode facing the incoming light source (see: Figure 5-5).

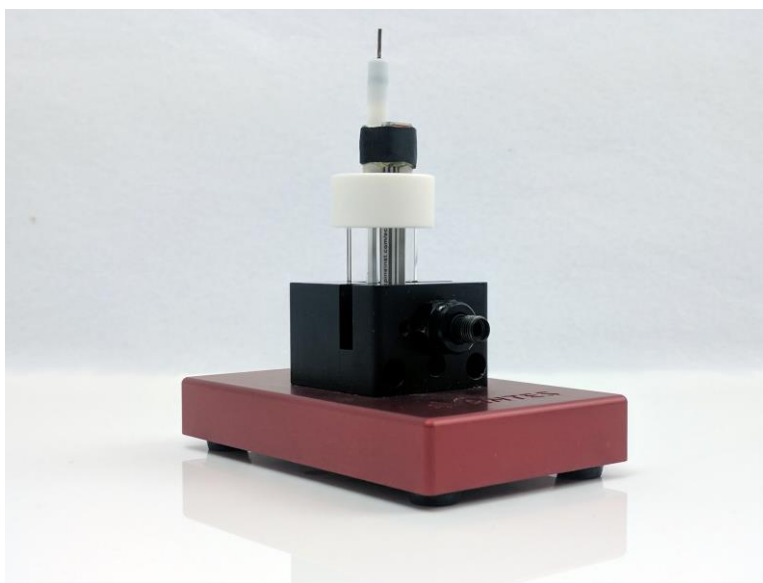

**Figure 5-5. Patterned Side of Honeycomb Electrode Faces Light Source**

## 5.4 Potentiostat Connection

Cell cables for connecting the electrode card to various Pine Research potentiostat models are available (see: Figure 5-6). Each cable mates with the electrode card via a mini-USB connector at one end of the cable. The other end of the cable varies depending upon the potentiostat model. A generic cable for use with third-party potentiostats is also available.



**Figure 5-6. Cell Cables Compatible with the Honeycomb Spectroelectrochemical Cell**

### 5.4.1 Connecting to a WaveNow/WaveNano Potentiostat

The cell connector on the Pine Research WaveNow (and WaveNano) potentiostats is a standard HD-15 type connector. A suitable cell cable (see: Figure 5-6, part RRTPE05) is available to make a direct connection from the cell connector on the potentiostat to the mini-USB connection on the electrode card. Near the mini-USB connector, there is a white reference electrode “breakout” wire terminating at a small socket which mates with the pin at the top of the reference electrode (see: Figure 5-7).

### 5.4.2 Connecting to a WaveDriver 10/20 Potentiostat

The cell connector on a Pine Research WaveDriver 10 or WaveDriver 20 potentiostats is a large D-shell type connector. A suitable cell cable (see: Figure 5-6, part ACP2E09) is available to make a direct connection from the cell connector on the potentiostat to the mini-USB connection on the electrode card. Near the mini-USB connector, there is a white reference electrode “breakout” wire terminating at a small socket which mates with the pin at the top of the reference electrode (see: Figure 5-7).

### 5.4.3 Connection to a WaveDriver 40/100/200 Potentiostat

When connecting a Pine Research WaveDriver 40, WaveDriver 100, or WaveDriver 200 potentiostat to the electrode card, it is necessary to use two cables. The standard potentiostat cell cable included with the potentiostat is used together with a mini-USB-to-banana cell cable (see: Figure 5-6, part RRPECBL2) as described below for a third-party potentiostat (see: Section 5.4.4).

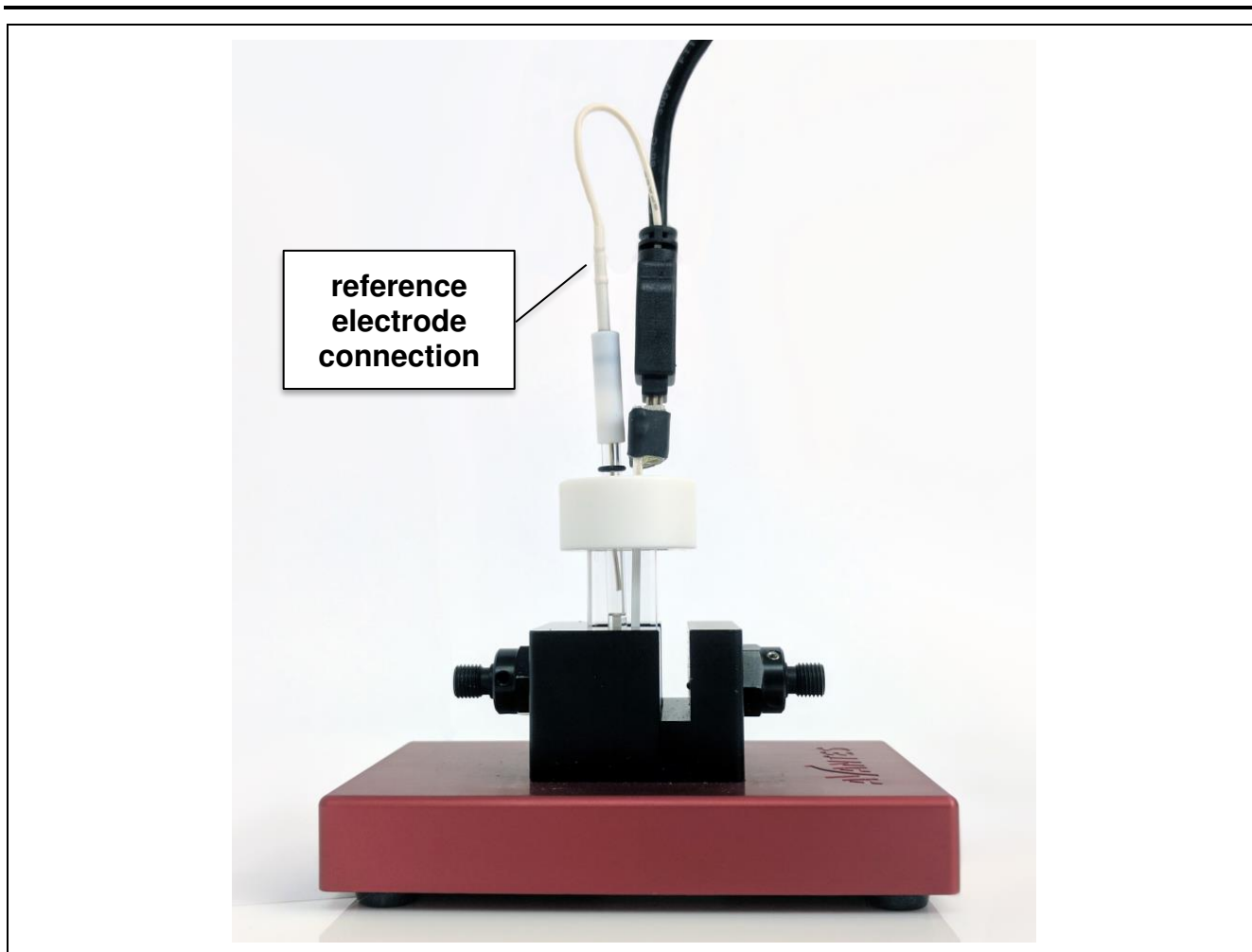

Figure 5-7. Connection to the Electrode Card and the Reference Electrode

#### 5.4.4 Connection to a Third-Party Potentiostat

A generic mini-USB-to-banana cell cable (see: Figure 5-6, part RRPECBL2) can be used to connect the electrode card to a third-party potentiostat. Each banana plug on this cable has a unique color indicating a particular electrode signal line (see: Table 5-1).

Color	Description	ID	Type
WHITE	Reference Electrode	REF	Sense
GREEN	Counter Electrode	CTR	Drive
RED	Working Electrode	WRK	Drive
ORANGE	Working Electrode		Sense

Table 5-1. Electrode Color Code for Generic mini-USB-to-Banana Cable

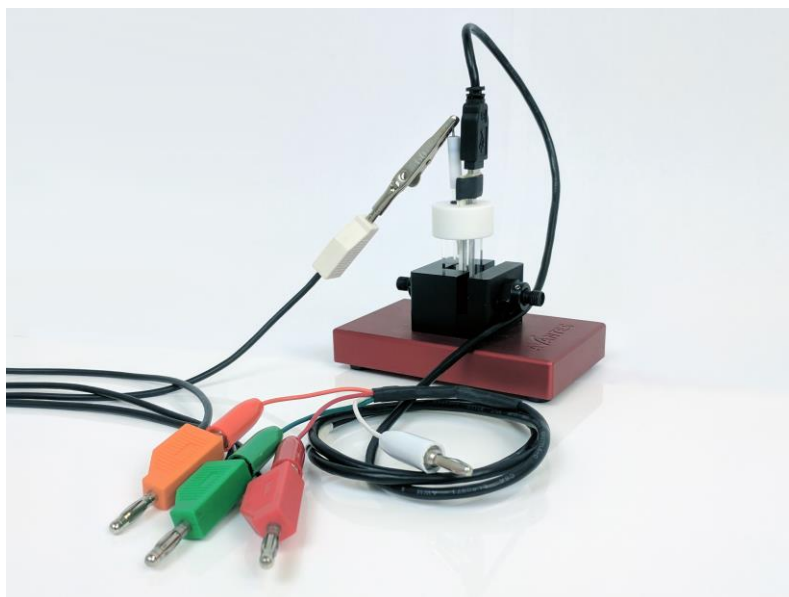

**Figure 5-8. Connecting the Electrode Card using a Generic Cell Cable**

A standard third-party potentiostat cell cable normally has signal lines for connections to the counter, working, and reference electrodes. The reference electrode line on the standard cell cable for the potentiostat can be directly connected to the pin at the top of the reference electrode (using an alligator clip). However, for the other electrode connections, a generic mini-USB-to-banana cable must be used to bridge from the standard cell cable to the electrode card in the cuvette (see: Figure 5-8).

The green banana plug on the generic cell cable corresponds to the counter electrode drive signal. This banana plug should be connected to the counter electrode drive line on the standard cell cable for the potentiostat.

The red banana plug on the generic cell cable corresponds to the working electrode drive signal. This banana plug should be connected to the working electrode drive line on the standard cell cable for the potentiostat.

The orange banana plug on the generic cell cable corresponds to the working electrode sense signal. This banana plug should be connected to the working electrode sense line on the standard cell cable for the potentiostat. Note that not all potentiostats have a separate working electrode sense line. If the potentiostat does not have a separate working electrode sense line, then the orange banana plug can be left unconnected, or it can be shorted together with the red banana plug.

The white banana plug on the generic cell cable should be left unconnected.



**INFO:**

**The white banana plug on the generic cell cable is normally NOT connected to the potentiostat. This plug connects to a small diagnostic disk electrode spot on the electrode card which is not used for spectroelectrochemistry.**

## 5.5 Light Source/Spectrometer Connection

Pine Research potentiostats are capable of working in conjunction with certain fiber-optic spectrometer systems offered by Avantes ([www.avantes.com](http://www.avantes.com)). The AfterMath software package offered by Pine Research can synchronize electrochemical measurements (via the potentiostat) with spectroscopic measurements (via the spectrometer) and intelligently present the results in an integrated fashion.

When connecting the fiber optic lines to the cuvette holder, the fiber optic line from the light source should illuminate the side of the electrode card which has the metal electrode patterns. After the light exits the cuvette, it is carried to the detector using a second fiber optic line.



Figure 5-9. Light Source Must Illuminate the Electrode Card on the Side with the Metal Electrodes

## 6. Example Experiments

### 6.1 Basic Spectroelectrochemical Experiments

When learning a new electrochemical technique, it is always best to begin by studying a well-known and well-behaved electrochemical system. The sections below describe two such systems: potassium ferricyanide and methyl viologen. Both of these systems exhibit reversible redox behavior and have been extensively characterized in the scientific literature.

#### 6.1.1 Ferricyanide/Ferrocyanide

Ferricyanide ( $Fe(CN)_6^{3-}$ ) is a yellow anion that undergoes a reversible reduction around  $0.2\text{ V vs SCE}$  to form a colorless anion called ferrocyanide ( $Fe(CN)_6^{4-}$ ) (see: Equation 6-1).

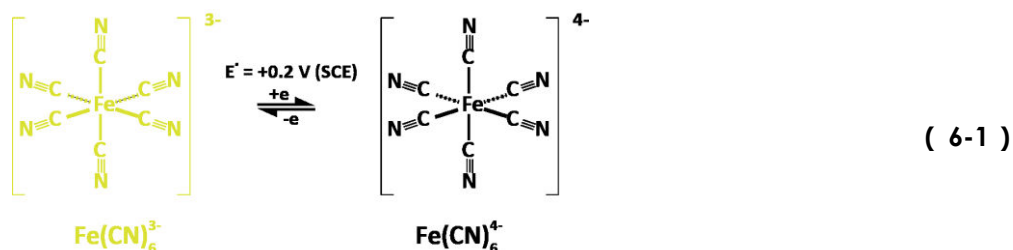

A simple spectroelectrochemical study of ferricyanide can be performed by applying two different potentials to an electrolyte solution containing ferricyanide ( $1.0\text{ mM Fe(CN)}_6^{3-}$  in  $100\text{ mM KNO}_3$ ). One potential must be sufficiently negative to reduce the anion to the colorless ferrocyanide species, while the other potential must be sufficiently positive to oxidize the anion to the yellow ferricyanide species.

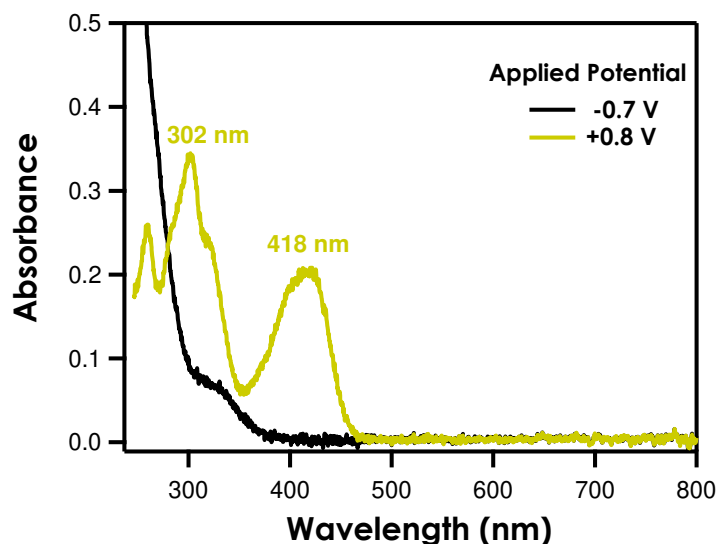

Figure 6-1. Absorption Spectra of Ferricyanide (yellow trace) and Ferrocyanide (black trace)

A UV/Vis spectrum acquired while the more positive potential (e.g.,  $+0.8\text{ V}$ ) is applied to the honeycomb working electrode exhibits two prominent absorption peaks (see: Figure 6-1, yellow trace). These two absorption peaks are the reason that the oxidized form of the anion ( $Fe(CN)_6^{3-}$ , ferricyanide) has a yellow color. However, if a large negative overpotential (e.g.,  $-0.7\text{ V}$ ) is applied to the honeycomb working



electrode, ferricyanide is reduced to the colorless ferrocyanide anion ( $Fe(CN)_6^{4-}$ ), and the two peaks disappear (see: Figure 6-1, black trace).

The experimental parameters used to obtain these spectroelectrochemical results are shown below. Note that these parameters are shown as they appear using the AfterMath software package from Pine Research (see: Figure 6-2).

The screenshot displays the 'SPECE Parameters (0002)' window, titled 'Parameters for Spectroelectrochemistry'. The interface includes a menu bar with 'Audit', 'Perform', 'Create copy', and 'I Feel Lucky'. Below the menu are tabs for 'Basic', 'Advanced', 'Filters', 'Post Experiment Conditions', and 'Post Experiment Processing'. The 'Basic' tab is active, showing several parameter groups:

- Acquisition Parameters:** Includes a checked 'Use Reference Settings' checkbox.
- Lamp Control:** Includes a checked 'Use Reference Settings' checkbox.
- Wavelength Limits:**
  - Minimum Wavelength: 200 nm (with 'Use Instrument Default' checked)
  - Maximum Wavelength: 1100 nm (with 'Use Instrument Default' checked)
- Sweep limits:**
  - Segments: 1
  - Initial potential: 0.8 V (with 'rising' selected)
  - Final potential: -0.7 V
- Step parameters:**
  - Amplitude: 1.5 V
  - Period: 30 s
- Sampling:** Number of intervals: 3000
- Electrode K1 ranges:**
  - Initial Range: Default mV, Autorange: On
  - Default: Default  $\mu A$ , Autorange: Off

**Figure 6-2. Parameters for the Ferricyanide Reduction to Ferrocyanide**

Experiments that utilize a single potential step (like the experiment above with ferricyanide) offer a quick and easy way to determine the basic absorption spectrum of the oxidized and reduced form of a compound that undergoes a rapid single-step redox event. For such a redox couple, a relatively short electrolysis period is sufficient to convert all of the species near the honeycomb working electrode from one form to the other. In the above example, only 30 seconds is required (see: Figure 6-2, the **Period** parameter).

Other electrochemical systems with slower redox kinetics may require a longer period of time to come to equilibrium with the electrode potential. For these slow redox couples, the electrolysis period may need to be much longer (several minutes), and it is common practice to use many smaller potential steps (see: Figure 6-2, the **Amplitude** parameter) to slowly convert the redox species from one form to the other.

To illustrate how a set of spectra acquired at smaller potential increments might appear, the ferricyanide/ferrocyanide system can be examined over a range of potentials spanning the standard potential for this redox couple (see: Figure 6-4, from 100 *mV* to 450 *mV*). In the parameter set shown below, the potential is incrementally stepped from 100 *mV* to 450 *mV vs Ag/AgCl* in 50 *mV* steps.

**Figure 6-3. Parameters to Obtain Incremental Absorption Spectra**

At the initial potential (100 *mV*), all of the anions near the honeycomb working electrode are reduced to the colorless ferrocyanide form (see: Figure 6-4, black trace). At more positive potentials, some of anions begin to be oxidized to the yellow ferricyanide form, and the corresponding absorption peaks begin to appear in the spectra. At very positive potentials, all of the anions are converted to the ferricyanide form, and the absorption peaks reach their maximum and do not grow any higher even if more positive potentials are applied (see: Figure 6-4, the peaks observed at 400 *mV* and 450 *mV* are essentially the same size).

$$A_{420 \text{ nm}} = 0.78 = \varepsilon * (0.17 \text{ cm})(0.0045 \text{ M}) \quad (6-2)$$

$$\Rightarrow \varepsilon = 1020 \text{ M}^{-1}\text{cm}^{-1}$$

Using the Beer-Lambert relationship (see: Equation 6-2), the molar extinction coefficient for ferricyanide can be determined from the size of the absorption peak. The absorption value observed at 420 *nm* is 0.78, and the optical path length for the cuvette is known (0.17 *cm*, see: Figure 3-2). The extinction

coefficient computed for ferricyanide at 420 nm ( $1020 M^{-1}cm^{-1}$ ) is comparable to a known value reported elsewhere ( $1040 M^{-1}cm^{-1}$ ).

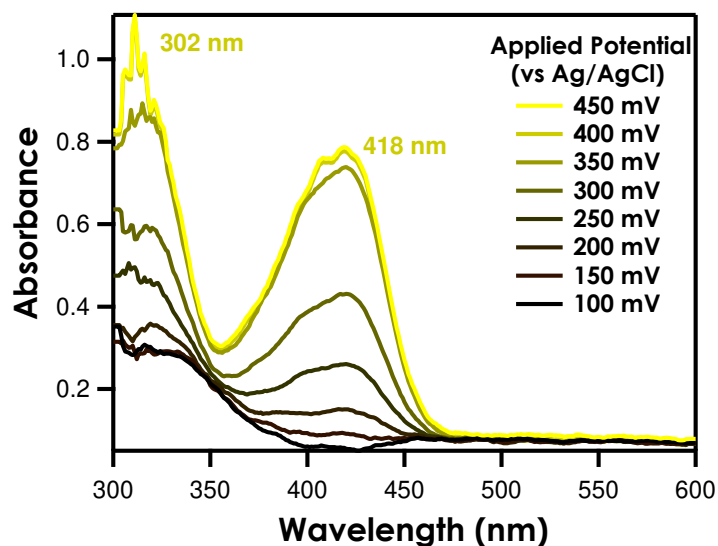
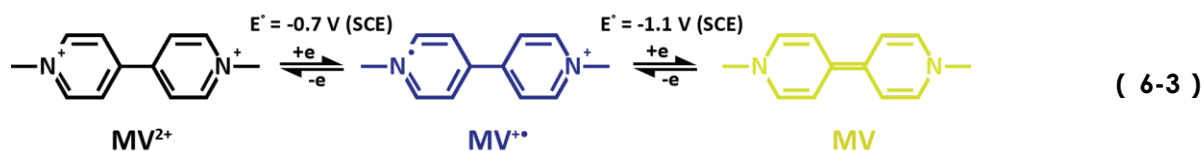

Figure 6-4. Absorption Spectra for the Ferricyanide/Ferrocyanide Redox Couple at Various Potentials

### 6.1.2 Methyl Viologen

Methyl viologen ( $MV^{2+}$ ) is a colorless compound that undergoes two reversible reductions. The first reduction occurs around  $-0.7 V$  vs SCE to form the methyl viologen radical cation ( $MV^{+\bullet}$ ) while the second reduction occurs around  $-1.1 V$  vs SCE to form neutral methyl viologen ( $MV$ ); these compounds are blue and light yellow, respectively (see: Equation 6-3).



A simple study of methyl viologen can be performed by applying a sufficient voltage capable of reducing the methyl viologen while simultaneously obtaining UV/Vis absorption spectra. If, for example,  $-1.0 V$  is applied to a  $0.1 mM$   $MV^{2+}$  solution (in  $100 mM$   $KNO_3$ ), it is expected that  $MV^{2+}$  (colorless) will be reduced to the blue  $MV^{+\bullet}$  (blue). Because the two compounds have very different absorbance profiles, this experiment can be monitored spectroscopically (see: Figure 6-5). Parameters used to obtain these spectra are provided (see: Figure 6-6).

As with the ferri/ferrocyanide example (see: Section 6.1.1), a spectroelectrochemical examination of methyl viologen can be performed using smaller potential steps. Smaller potential steps allow the accurate determination of the extinction coefficients for both  $MV^{+\bullet}$  and  $MV$  ( $\epsilon_{604 nm} = 13900 M^{-1}cm^{-1}$  for  $MV^{+\bullet}$  and  $\epsilon_{380 nm} \approx 42500 M^{-1}cm^{-1}$  for  $MV$ ). The data for such an experiment is not shown here; however, this experiment is suggested as a good practice system for those learning spectroelectrochemistry for the first time.

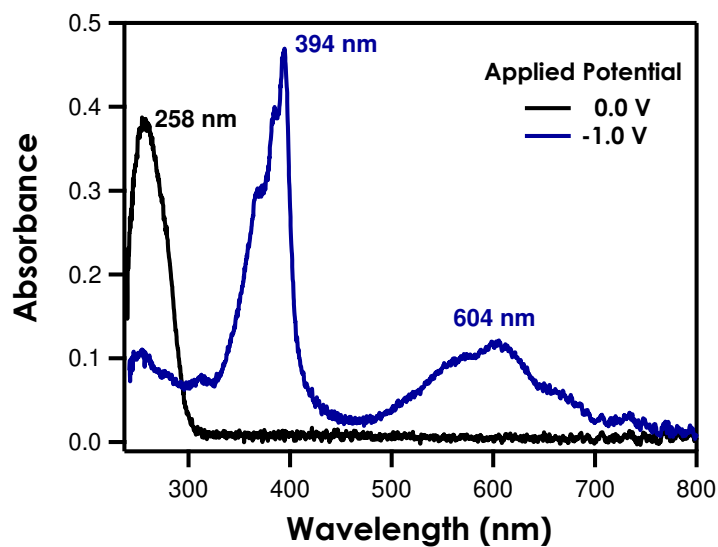

Figure 6-5. Absorption Spectra of  $MV^{2+}$  (black trace) and  $MV^{+\bullet}$  (blue trace)

SPECE Parameters (0002)  
Parameters for Spectroelectrochemistry

Pine WaveNow (SN 2408002)/Avantes AvaS Audit Perform Create copy "I Feel Lucky"

Basic **Advanced** Filters Post Experiment Conditions Post Experiment Processing

Acquisition Parameters  
 Use Reference Settings

Lamp Control  
 Use Reference Settings

Wavelength Limits  
Minimum Wavelength: 200 nm  Use Instrument Default  
Maximum Wavelength: 1100 nm  Use Instrument Default

Sweep limits  
Segments: 1  
Initial potential: 0 mV  rising  falling  
Final potential: -1 V

Step parameters  
Amplitude: 1 V  
Period: 30 s

Sampling  
Number of intervals: 3000

Electrode K1 ranges  
Initial Range: Default mV  Autorange: On  
Default  $\mu A$   Off

Figure 6-6. Parameters for the Reduction of  $MV^{2+}$  to  $MV^{+\bullet}$

## 6.2 Measurement of Electrochemical Kinetics

Several physical processes occur simultaneously during an electrochemical reaction. These processes include electron transfer at the double-layer interface, chemical reactions proceeding or following an electron transfer step, and mass transport (such as diffusional transport) toward the electrode surface. To evaluate the relative rates, or electrochemical kinetics, of such processes, researchers often rely on spectroelectrochemistry. In a typical spectroelectrochemical experiment, the size of a well-known absorption peak (corresponding to a particular redox species) is measured as a function of time. In this type of experiment, the researcher must balance signal strength (absorbance) and time resolution as two trade-off parameters.

This case can be illustrated by again considering reversible ferricyanide/ferrocyanide redox couple (see: Equation 6-1). Recall that ferricyanide has two signature peaks in the visible range (302 nm and 418 nm) and ferrocyanide is colorless (see: Section 6.1.1 and Figure 6-1). Therefore, if a large, negative overpotential is applied to a solution of ferricyanide, it is expected that the size of the absorption peaks in the spectrum will decrease with time as ferricyanide is gradually reduced to ferrocyanide.

In the example below, a square waveform (see: Figure 6-7a) was applied to a 1 mM  $Fe(CN)_6^{3-}$  solution in 100 mM  $KNO_3$  in a honeycomb spectroelectrochemical cell. By monitoring the height of the absorption peaks at 302 nm and 418 nm as a function of time, the rate of the reduction process can be observed spectroscopically. At 100 seconds into the experiment, the applied potential changes from +0.8 V to -0.7 V, and a decrease in absorbance is observed as the yellow ferricyanide is reduced to colorless ferrocyanide (see: Figure 6-7b). At 220 seconds into the experiment, the applied potential is returned to its initial value (+0.8 V), and the absorbance peaks begin to increase in height.

By examining the electrolysis curves, it is possible to obtain valuable information about the timescale required for exhaustive electrolysis. For this redox couple with relatively fast redox kinetics, the time required for exhaustive electrolysis is dominated by diffusion of the redox species to the honeycomb working electrode. During the first 30 seconds after the potential is changed, the anions close to the electrode surface are rapidly oxidized (or reduced), causing a relatively fast change in the observed absorbance. But, complete conversion of all of the anions in the light path (*i.e.*, exhaustive electrolysis) requires much more time (at least another 100 seconds) to allow those anions initially further away from the electrode to eventually diffuse to the electrode surface.

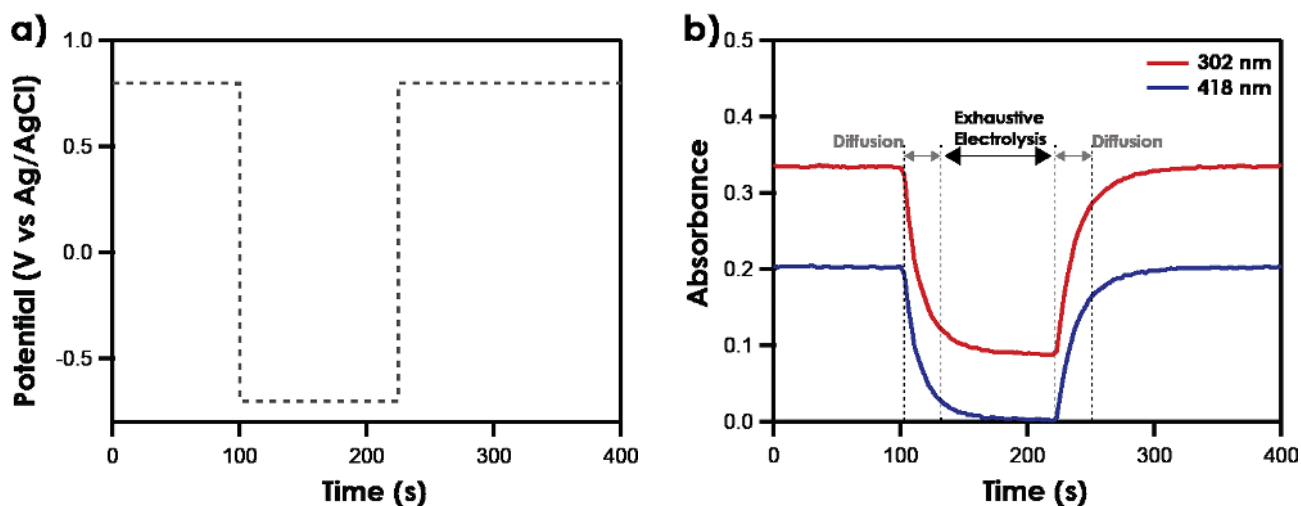

Figure 6-7. Applied Waveform and Absorbance Transients for Ferricyanide/Ferrocyanide System

## 7. Care and Storage

### 7.1 Component Storage

All cell components should be cleaned, dried, and stored carefully after each use. Potentiostat and spectrometer components should be turned off and maintained in a safe location. To avoid damage to the fiber optic cables, the cables should be disconnected from the cuvette holder and placed in a protective container.

### 7.2 Cleaning the Quartz Cell

The quartz cell can be cleaned by rinsing it with a solvent to remove any residual analyte and then rinsing with deionized water. The quartz cell is compatible with organic solvents, most acidic solutions, and basic solutions. The quartz cell is NOT COMPATIBLE with hydrofluoric acid or phosphoric acid.

### 7.3 Cleaning the Cell Cap

The cell cap is made of polyethylene terephthalate (PET). This plastic is compatible with water and most simple alcohols (including methanol, ethanol, and isopropanol). This plastic is NOT COMPATIBLE with methylene chloride or acetone. Before using a solvent to clean the cell cap, consult an appropriate reference source to assure that the solvent is compatible with PET. After rinsing with a compatible solvent, the cap may be dried using a stream of nitrogen or compressed air.

### 7.4 Cleaning the Honeycomb Electrode

Honeycomb electrodes cannot be cleaned using traditional polishing with an abrasive material. Rather, the electrode must be cleaned chemically (using a solvent or an acidic solution) or electrochemically (using an acidic solution while simultaneously applying an extreme potential to the electrode). Depending upon the amount and type of chemical contamination, it may or may not always be possible to completely clean the electrode surface.



**CAUTION:**

**Traditional polishing methods with aluminum oxide slurries are not appropriate for use with the honeycomb electrode card.**

In applications that generate heavily fouled electrode surfaces, chemical cleaning methods are often faster and more convenient than electrochemical methods. The choice of reagents or solvents used to clean the electrode chemically will depend upon the nature of the contaminant. In other cases where the surface is only mildly contaminated by trace impurities adsorbed on to the electrode surface (i.e., sub-monolayer amounts of material), the electrochemical cleaning method will often suffice to clean the surface. In more advanced applications, such as protein electrochemistry, additional post-cleaning steps may be required, such as chemical modification of the surface to increase the heterogeneous electron transfer rate.

#### 7.4.1 Chemical Methods

Depending upon the amount and type of contamination on the surface of the honeycomb electrode card, it may be possible to clean the electrode chemically. The ceramic substrate and electrode traces are compatible with most organic solvents and aqueous acid solutions. However, the (clear) insulating

silicon dioxide coating on the honeycomb electrode card is NOT COMPATIBLE with strongly basic solutions or hydrofluoric acid.

### 7.4.2 Electrochemical Method

For electrodes which are covered with only single monolayer quantity of organic adsorbents, the electrochemical method is often adequate. Though this method does not remove as many surfactants as the chemical method, it does supply a resulting cyclic voltammogram that can help one qualitatively assess whether the surface is clean (see: Figure 7-1).



**WARNING:**

**CORROSIVE SUBSTANCE**

**Wear proper personal protective equipment when working with corrosive substances.**

To electrochemically clean the Honeycomb electrode, follow these steps:

1. Prepare a dilute sulfuric acid solution ( $0.5\text{ M H}_2\text{SO}_4$ ).
2. Use a plastic pipette to fill the holes in the honeycomb working electrode with the sulfuric acid solution.
3. Place the Honeycomb electrode in an electrochemical cell (or small beaker) filled with the sulfuric acid solution along with a reference electrode.
4. Connect the counter, working, and reference electrodes to the potentiostat.
5. Set up the cyclic voltammetry cleaning parameters (see: Table 7-1).
6. Perform the cyclic voltammetry experiment.
7. Check to see if the electrode is clean (see: Figure 7-1). The experiment can be performed again if more cleaning is needed.



**INFO:**

**During the electrochemical cleaning process, certain features in the cyclic voltammogram grow or decay, eventually stabilizing to a reproducible trace (see: Figure 7-1).**

**When voltammogram traces begin to lay exactly on top of previous traces (typically after about 10-15 cycles), the cleaning process is completed.**

8. Remove the electrode card from solution and rinse the working electrode holes with deionized water using the plastic pipette.

After completing an electrochemical cleaning process, be sure to compare the final cyclic voltammogram to the expected response from a clean electrode. The characteristic peaks of a clean gold or platinum surface (see: Figure 7-1) are described below:

- A clean gold surface typically shows an onset of gold oxidation around  $1100\text{ mV vs. Ag/AgCl}$  and a sharp reduction peak around  $900\text{ mV vs. Ag/AgCl}$  (see: Figure 7-1a)
- A clean platinum surface typically shows an onset of platinum oxidation around  $600\text{ mV vs. Ag/AgCl}$ , a sharp reduction peak around  $450\text{ mV vs. Ag/AgCl}$ , and two hydrogen adsorption and desorption peaks (sometimes called the “butterfly region”) just below zero volts (see: Figure 7-1b).

Parameter	Platinum Electrode	Gold Electrode
Number of Segments	At least 20	At least 20
Initial Potential	-300 mV	-375 mV
Upper Potential	1700 mV	1800 mV
Lower Potential	-300 mV	-375 mV
Final Potential	-300 mV	-375 mV
Sweep Rate	500 mV/s	500 mV/s
Electrolyte	0.5 M H <sub>2</sub> SO <sub>4</sub>	0.5 M H <sub>2</sub> SO <sub>4</sub>

Table 7-1. Electrochemical Cleaning Parameters for Honeycomb Electrodes

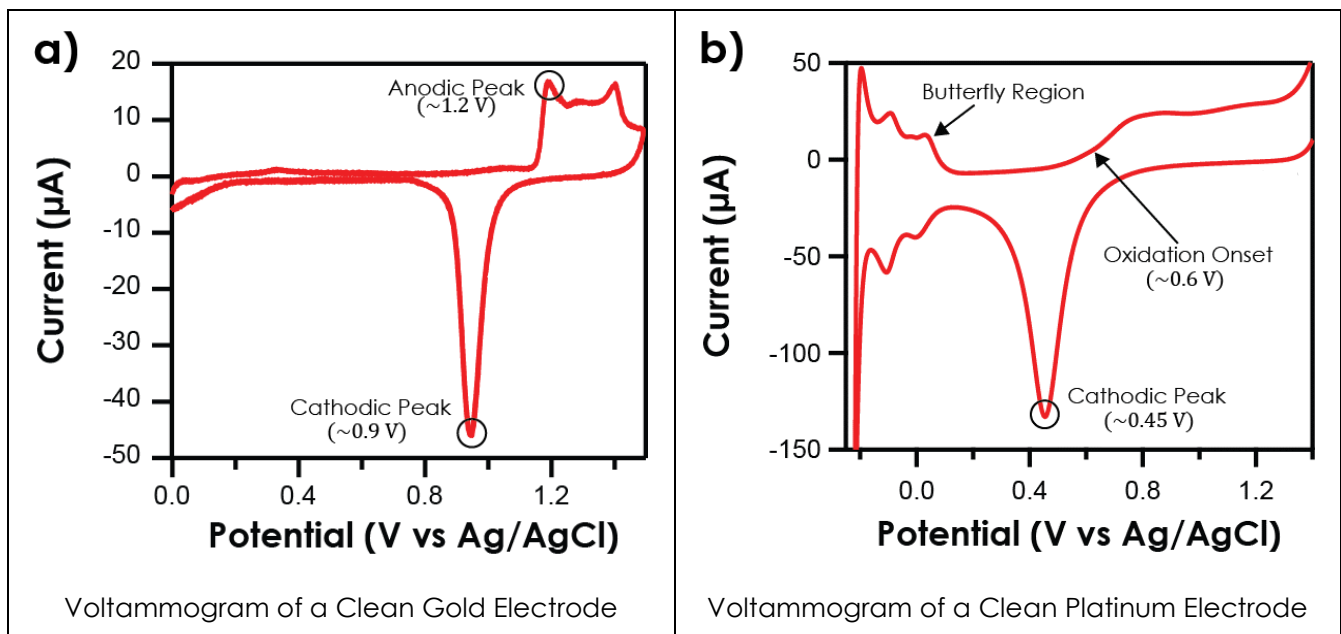

Figure 7-1. Characteristic Voltammograms for Clean Honeycomb Electrode Cards



## 8. Bibliography

The Honeycomb spectroelectrochemistry cell is widely cited by researchers around the world. The bibliography below is a list of several scientific reports which report the use of this cell.

- (1) Shova, S.; Vlad, A.; Cazacu, M.; Krzystek, J.; Bucinsky, L.; Breza, M.; Darvasiová, D.; Raptá, P.; Cano, J.; Telser, J.; et al. A Five-Coordinate Manganese(III) Complex of a Salen Type Ligand with a Positive Axial Anisotropy Parameter D. *Dalton Trans.* **2017**, 46 (35), 11817–11829. <https://doi.org/10.1039/C7DT01809F>.
- (2) Kellett, C. W.; Swords, W. B.; Turlington, M. D.; Meyer, G. J.; Berlinguette, C. P. Resolving Orbital Pathways for Intermolecular Electron Transfer. *Nat. Commun.* **2018**, 9 (1), 4916. <https://doi.org/10.1038/s41467-018-07263-1>.
- (3) Ohui, K.; Afanasenko, E.; Bacher, F.; Ting, R. L. X.; Zafar, A.; Blanco-Cabra, N.; Torrents, E.; Dömötör, O.; May, N. V.; Darvasiova, D.; et al. New Water-Soluble Copper(II) Complexes with Morpholine–Thiosemicarbazone Hybrids: Insights into the Anticancer and Antibacterial Mode of Action. *J. Med. Chem.* **2019**, 62 (2), 512–530. <https://doi.org/10.1021/acs.jmedchem.8b01031>.
- (4) Al-Yasari, A. Synthesis, Non-Linear Optical and Electrochemical Properties of Novel Organoimido Polyoxometalate Derivatives. Ph.D. Dissertation, University of East Anglia: Norwich, United Kingdom, 2016.
- (5) E. Büchel, G.; Kossatz, S.; Sadique, A.; Raptá, P.; Zalibera, M.; Bucinsky, L.; Komorovsky, S.; Telser, J.; Eppinger, J.; Reiner, T.; et al. Cis -Tetrachlorido-Bis(Indazole)Osmium(IV) and Its Osmium(III) Analogues: Paving the Way towards the Cis -Isomer of the Ruthenium Anticancer Drugs KP1019 and/or NKP1339. *Dalton Trans.* **2017**, 46 (35), 11925–11941. <https://doi.org/10.1039/C7DT02194A>.
- (6) Shova, S.; Vlad, A.; Cazacu, M.; Krzystek, J.; Ozarowski, A.; Malček, M.; Bucinsky, L.; Raptá, P.; Cano, J.; Telser, J.; et al. Dinuclear Manganese(III) Complexes with Bioinspired Coordination and Variable Linkers Showing Weak Exchange Effects: A Synthetic, Structural, Spectroscopic and Computation Study. *Dalton Trans.* **2019**. <https://doi.org/10.1039/C8DT04596H>.
- (7) Yang, Z. (Alice); Pazdzior, R.; Yee, J.; Rafferty, S. Reduction Potential and Heme-Pocket Polarity in Low Potential Cytochrome B5 of *Giardia Intestinalis*. *J. Inorg. Biochem.* **2016**, 158, 110–114. <https://doi.org/10.1016/j.jinorgbio.2016.02.021>.
- (8) Salpage, S. R.; Paul, A.; Som, B.; Banerjee, T.; Hanson, K.; Smith, M. D.; Vannucci, A. K.; Shimizu, L. S. Structural, Electrochemical and Photophysical Properties of an Exocyclic Di-Ruthenium Complex and Its Application as a Photosensitizer. *Dalton Trans.* **2016**, 45 (23), 9601–9607. <https://doi.org/10.1039/C6DT01377E>.
- (9) Pourrieux, G.; Abate, P. O.; Vergara, M. M.; Katz, N. E. Redox-Induced Linkage Isomerization Detected in [Ru(NH<sub>3</sub>)<sub>5</sub>(NVF)](PF<sub>6</sub>)<sub>2</sub>(NVF=N-Vinylformamide). *Inorg. Chem. Commun.* **2016**, 66, 90–93. <https://doi.org/10.1016/j.inoche.2016.02.015>.
- (10) Liang, Z.; Kang, M.; Payne, G. F.; Wang, X.; Sun, R. Probing Energy and Electron Transfer Mechanisms in Fluorescence Quenching of Biomass Carbon Quantum Dots. *ACS Appl. Mater. Interfaces* **2016**, 8 (27), 17478–17488. <https://doi.org/10.1021/acsami.6b04826>.
- (11) Kennedy, S. R.; Kozar, M. N.; Yennawar, H. P.; Lear, B. J. Synthesis and Characterization of the Gold Dithiolene Monoanion, (Bu<sub>4</sub>N)[Au(Pdt=2,3-Pyrazinedithiol)<sub>2</sub>]. *Polyhedron* **2016**, 103, 100–104. <https://doi.org/10.1016/j.poly.2015.09.023>.

- (12) Adams, R. E.; Schmehl, R. H. Micellar Effects on Photoinduced Electron Transfer in Aqueous Solutions Revisited: Dramatic Enhancement of Cage Escape Yields in Surfactant Ru(II) Diimine Complex/[Ru(NH<sub>3</sub>)<sub>6</sub>]<sup>2+</sup> Systems. *Langmuir* **2016**, *32* (34), 8598–8607. <https://doi.org/10.1021/acs.langmuir.6b02193>.
- (13) Zhao, Y.; Vargas-Barbosa, N. M.; Strayer, M. E.; McCool, N. S.; Pandelia, M.-E.; Saunders, T. P.; Swierk, J. R.; Callejas, J. F.; Jensen, L.; Mallouk, T. E. Understanding the Effect of Monomeric Iridium(III/IV) Aquo Complexes on the Photoelectrochemistry of IrO<sub>x</sub>·nH<sub>2</sub>O-Catalyzed Water-Splitting Systems. *J. Am. Chem. Soc.* **2015**, *137* (27), 8749–8757. <https://doi.org/10.1021/jacs.5b03470>.
- (14) Pazdzior, R.; Yang, Z. (Alice); Mesbahuddin, M. S.; Yee, J.; van der Est, A.; Rafferty, S. Low Reduction Potential Cytochrome b<sub>5</sub> Isoforms of *Giardia Intestinalis*. *Exp. Parasitol.* **2015**, *157*, 197–201. <https://doi.org/10.1016/j.exppara.2015.08.004>.
- (15) DiMarco, B. N.; O'Donnell, R. M.; Meyer, G. J. Cation-Dependent Charge Recombination to Organic Mediators in Dye-Sensitized Solar Cells. *J. Phys. Chem. C* **2015**, *119* (37), 21599–21604. <https://doi.org/10.1021/acs.jpcc.5b07342>.
- (16) Zhong, F.; Lisi, G. P.; Collins, D. P.; Dawson, J. H.; Pletneva, E. V. Redox-Dependent Stability, Protonation, and Reactivity of Cysteine-Bound Heme Proteins. *Proc. Natl. Acad. Sci.* **2014**, *111* (3), E306–E315. <https://doi.org/10.1073/pnas.1317173111>.
- (17) Thomsen, J. M.; Sheehan, S. W.; Hashmi, S. M.; Campos, J.; Hintermair, U.; Crabtree, R. H.; Brudvig, G. W. Electrochemical Activation of Cp\* Iridium Complexes for Electrode-Driven Water-Oxidation Catalysis. *J. Am. Chem. Soc.* **2014**, *136* (39), 13826–13834. <https://doi.org/10.1021/ja5068299>.
- (18) Bischof, A. M.; Zhang, S.; Meyer, T. Y.; Lear, B. J. Quantitative Assessment of the Connection between Steric Hindrance and Electronic Coupling in 2,5-Bis(Alkoxy)Benzene-Based Mixed-Valence Dimers. *J. Phys. Chem. C* **2014**, *118* (24), 12693–12699. <https://doi.org/10.1021/jp504887s>.
- (19) Navarathne, D.; Skene, W. G. Towards Electrochromic Devices Having Visible Color Switching Using Electronic Push–Push and Push–Pull Cinnamaldehyde Derivatives. *ACS Appl. Mater. Interfaces* **2013**, *5* (23), 12646–12653. <https://doi.org/10.1021/am4040009>.
- (20) King, J. D.; McIntosh, C. L.; Halsey, C. M.; Lada, B. M.; Niedzwiedzki, D. M.; Cooley, J. W.; Blankenship, R. E. Metalloproteins Diversified: The Auracyanins Are a Family of Cupredoxins That Stretch the Spectral and Redox Limits of Blue Copper Proteins. *Biochemistry* **2013**, *52* (46), 8267–8275. <https://doi.org/10.1021/bi401163g>.
- (21) Kim, J.; Yennawar, H. P.; Lear, B. J. Synthesis and Characterization of Ruthenium Polypyridyl Complexes with Hydroxypyridine Derivatives: Effect of Protonation and Ethylation at the Pyridyl Nitrogen. *Dalton Trans.* **2013**, *42* (44), 15656–15662. <https://doi.org/10.1039/C3DT52094C>.
- (22) Palmer, J. H.; Lancaster, K. M. Molecular Redox: Revisiting the Electronic Structures of the Group 9 Metalloporphyrins. *Inorg. Chem.* **2012**, *51* (22), 12473–12482. <https://doi.org/10.1021/ic3018826>.
- (23) Orlowska, E.; Babak, M. V.; Dömötör, O.; Enyedy, E. A.; Raptá, P.; Zalibera, M.; Bučinský, L.; Malček, M.; Govind, C.; Karunakaran, V.; et al. NO Releasing and Anticancer Properties of Octahedral Ruthenium–Nitrosyl Complexes with Equatorial 1H-Indazole Ligands. *Inorg. Chem.* **2018**, *57* (17), 10702–10717. <https://doi.org/10.1021/acs.inorgchem.8b01341>.
- (24) Schorsch, M.; Kramer, M.; Goss, T.; Eisenhut, M.; Robinson, N.; Osman, D.; Wilde, A.; Sadaf, S.; Brückler, H.; Walder, L.; et al. A Unique Ferredoxin Acts as a Player in the Low-Iron Response of Photosynthetic Organisms. *Proc. Natl. Acad. Sci.* **2018**, *115* (51), E12111–E12120. <https://doi.org/10.1073/pnas.1810379115>.

## 9. Glossary

<b>Anodic Current</b>	Flow of charge at an electrode as a result of an oxidation reaction occurring at the electrode surface. For a working electrode immersed in a test solution, an anodic current corresponds to flow of electrons out of the solution and into the electrode.
<b>Auxiliary Electrode</b>	(see: Counter Electrode)
<b>Banana Cable</b>	A banana cable is a single-wire (one conductor) signal cable often to make connections between various electronic instruments. Each end of the cable has a banana plug. The plug consists of a cylindrical metal pin about 25 mm (one inch) long, with an outer diameter of about 4 mm, which can be inserted into a matching banana jack.
<b>Banana Jack</b>	Female banana connector
<b>Banana Plug</b>	Male banana connector
<b>BNC Connector</b>	The BNC (Bayonet Neill-Concelman) connector is a very common type of used for terminating coaxial cables.
<b>Cathodic Current</b>	Flow of charge at an electrode as a result of a reduction reaction occurring at the electrode surface. For a working electrode immersed in a test solution, a cathodic current corresponds to flow of electrons out of the electrode and into the solution.
<b>Counter Electrode</b>	The counter electrode, also called the auxiliary electrode, is one of three electrodes found in a typical three-electrode voltammetry experiment. The purpose of the counter electrode is to carry the current across the solution by completing the circuit back to the potentiostat.
<b>Cyclic Voltammetry</b>	An electroanalytical method where the working electrode potential is repeatedly swept back and forth between two extremes while the working electrode current is measured.
<b>Electroactive</b>	An adjective used to describe a molecule or ion capable of being oxidized or reduced at an electrode surface.
<b>Electrode</b>	An electrode is an electrical conductor used to make contact with a nonmetallic part of a circuit.
<b>Electrostatic Discharge (ESD)</b>	The rapid discharge of static electricity to ground. Sensitive electronics in the path of an ESD event may suffer damage.
<b>Faradaic Current</b>	The portion of the current observed in an electroanalytical experiment that can be attributed to one or more redox processes occurring at an electrode surface.
<b>Half-Reaction</b>	A balanced chemical equation showing how various molecules or ions are reduced (or oxidized) at an electrode surface.
<b>Linear Sweep Voltammetry</b>	Experiment in which the working electrode potential is swept from initial value to final value at a constant rate while the current is measured.

---

<b>Non-Faradaic Current</b>	The portion of the current observed in an electroanalytical experiment that cannot be attributed to any redox processes occurring at an electrode surface.
<b>Overpotential</b>	The overpotential is the difference between the formal potential of a half-reaction and the potential actually being applied to the working electrode.
<b>Oxidation</b>	Removal of electrons from an ion or molecule.
<b>Redox</b>	An adjective used to describe a molecule, ion, or process associated with an electrochemical reaction.
<b>Reduction</b>	Addition of electrons to an ion or molecule.
<b>Reference Electrode</b>	A reference electrode has a stable and well-known thermodynamic potential. The high stability of the electrode potential is usually achieved by employing a redox system with constant (buffered or saturated) concentrations of the ions or molecules involved in the redox half-reaction.
<b>Standard Electrode Potential</b>	A thermodynamic quantity expressing the free energy of a redox half-reaction in terms of electric potential.
<b>Sweep Rate</b>	The rate at which the electrode potential is changed when performing a sweep voltammetry technique such as cyclic voltammetry.
<b>Three-Electrode Cell</b>	A common electrochemical cell arrangement consisting of a working electrode, a reference electrode, and a counter electrode.
<b>Voltammogram</b>	A plot of current vs. potential from an electroanalytical experiment in which the potential is swept back and forth between two limits.
<b>Working Electrode</b>	The electrode at which the redox process of interest occurs. While there may be many electrodes in an electrochemical cell, the focus of an experiment is typically only on a particular half-reaction occurring at the working electrode.
<b>Working Electrode Drive</b>	The connection on a potentiostat or galvanostat through which charge flows to or from a working electrode. Drive lines have low impedance to allow significant charge flow (current) through the working electrode.
<b>Working Electrode Sense</b>	The connection on a potentiostat or galvanostat which measures the potential of a working electrode. Sense lines have a high input impedance so that the potential can be measured without significant charge flow (current) through the sense line.

---

## 10. Contact Support

After reviewing the content of this user guide, please contact Pine Research Instrumentation should you have any issues or questions with regard to the use of the instrument, accessories, or software.

Contact us anytime by the methods provided below:

### 10.1 Online

Our website has a contact form, which accepts users to submit technical support requests directly to Pine Research. Visit [www.pineresearch.com/contact](http://www.pineresearch.com/contact).

### 10.2 By E-mail

Send an email to [pinewire@pineresearch.com](mailto:pinewire@pineresearch.com). This is the general sales email and our team will ensure your email is routed to the most appropriate technical support staff available. Our goal is to respond to emails within 24 hours of receipt.

### 10.3 By Phone

Our offices are located in Durham, NC in the eastern US time zone. We are available by phone Monday through Friday from 9 AM EST to 5 PM EST. You can reach a live person by calling +1 (919) 782-8320.

